

CIRCUIT VITAL

# VITAL!

Bois et bois lamellé-collé traité en autoclave classe IV, bois tropical, panneau de coffrage, métal peint à la poudre, polyéthylène, HPL et plastique recyclé.

## DP600

GRUPO A  
GROUP A  
GROUPE A

3,25 x 1,89 x 2,09 m.



EN 16630

- h > 1,4 m.
- 0,56 m.
- 40 Kg.
- 0,85 x 0,66 x 2,08 m.
- 6,25 x 4,89 m.
- 28,6 m<sup>2</sup>.

**A.1**

Rueda  
Wheel  
Roue

**A.2**

Peldaños  
Steps  
Echelons

**A.3**

Balanceo de caderas  
Hip seesaw  
Equilibre des hanches

**A.4**

Ciro de caderas  
Hip rotator  
Virement des hanches

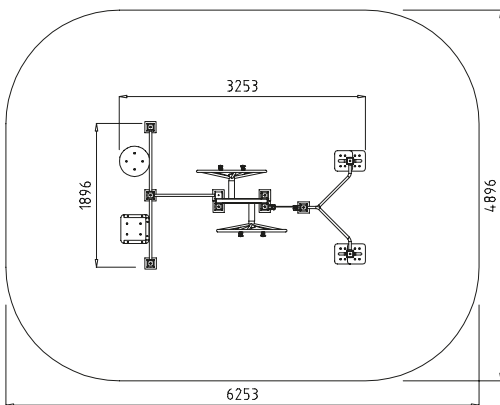
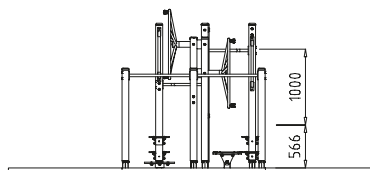
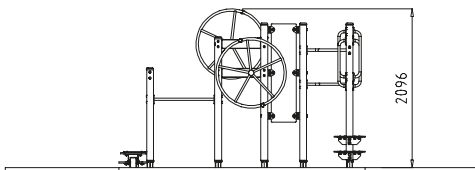

E: 1/100



# DP601

GRUPO B  
GROUP B  
GROUPE B

3,47 x 2,73 x 1,91 m.



EN 16630

h > 1,4 m.

0,42 m.

30 Kg.

1,78 x 0,92 x 1 m.

6,47 x 5,73 m.

34,85 m<sup>2</sup>.

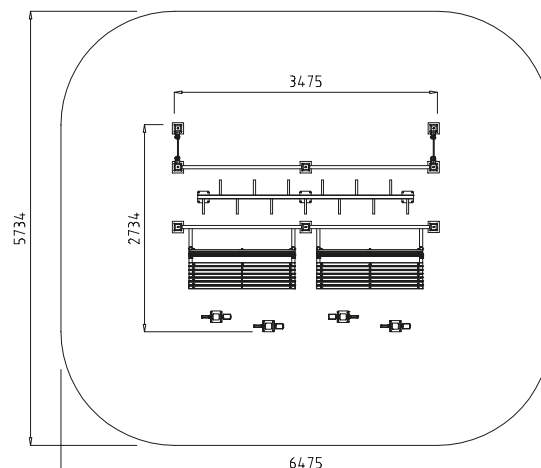
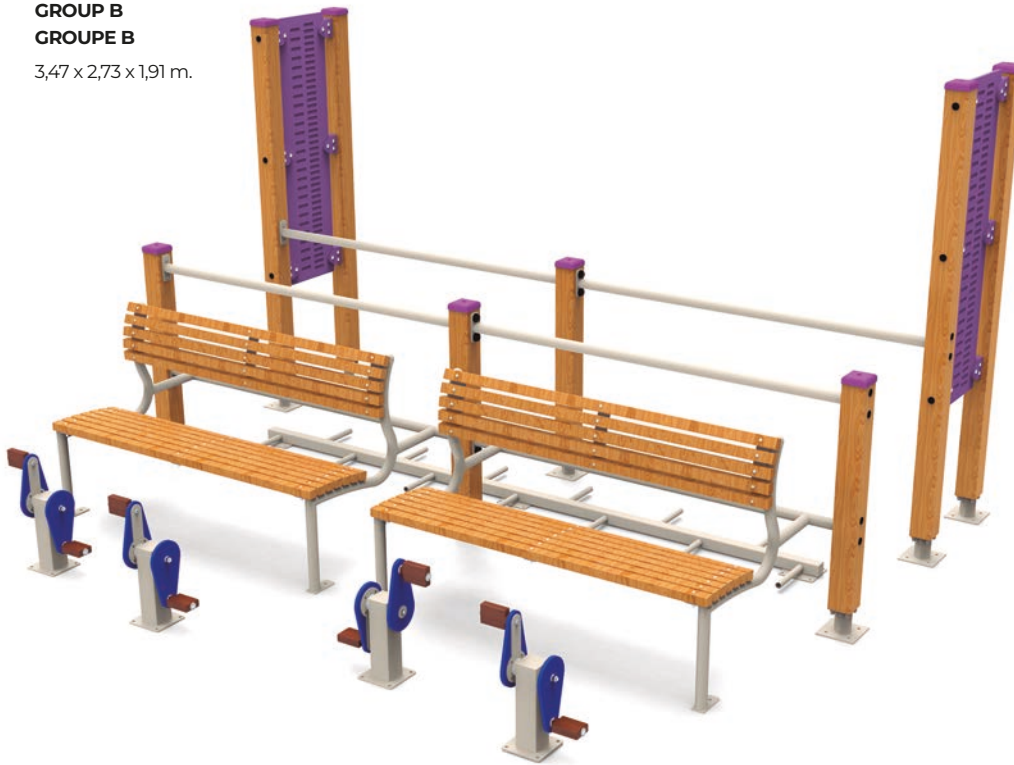

# DP602

GRUPO C  
GROUP C  
GROUPE C

4,22 x 2,08 x 2,26 m.



EN 16630

h > 1,4 m.

1,18 m.

90 Kg.

2,11 x 0,5 x 2,27 m.

7,22 x 5,08 m.

34,81 m<sup>2</sup>.



### C.1

Estiramiento de piernas  
Leg stretching  
Étirement des jambes

### C.2

Giro muñecas frontal y lateral  
Front and side wrist rotation  
Virement des poignets

### C.3

Estiramiento de espalda  
Back stretching  
Étirement de dos

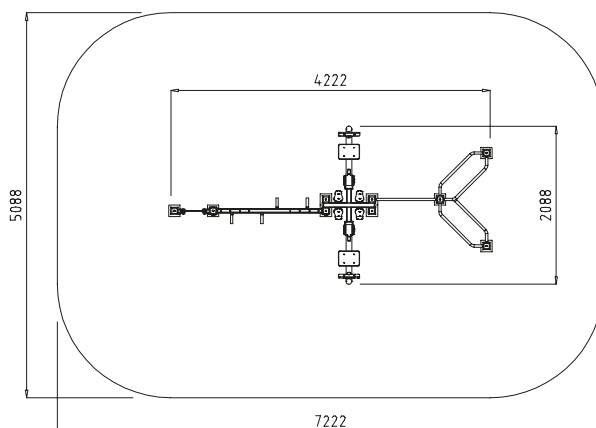
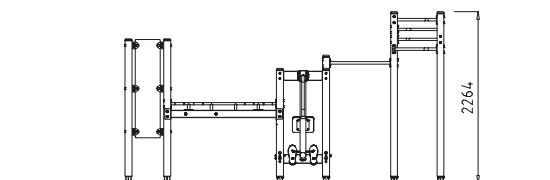
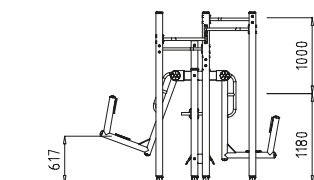

E: 1/100

# DP603

GRUPO D  
GROUP D  
GROUPE D

3,79 x 1,89 x 2,22 m.



- h > 1,4 m.
- 0,47 m.
- 35 Kg.
- 0,99 x 0,66 x 2,22 m.
- 6,79 x 4,89 m.
- 31,57 m<sup>2</sup>.



- D.1**  
Estiramiento espalda  
Back stretching  
Étirement du dos
- D.2**  
Serpiente  
Snake  
Serpent
- D.3**  
Sentadilla  
Squat  
Assise

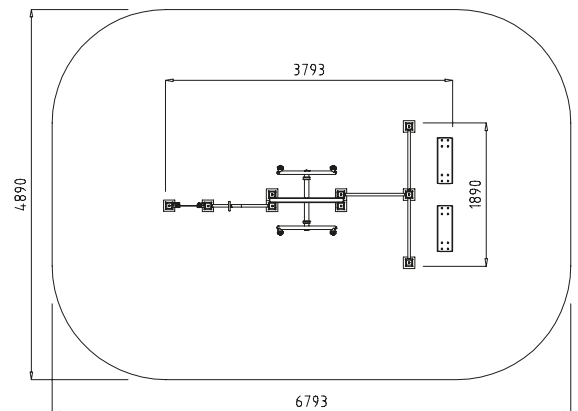
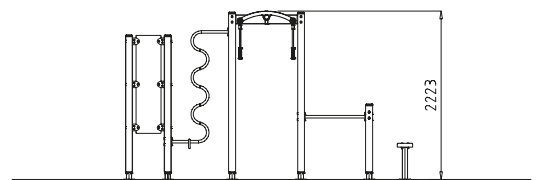
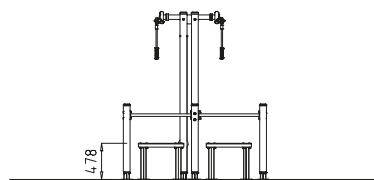





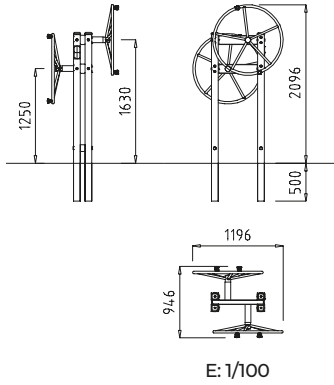

E: 1/100

## DP600A1

RUEDA  
WHEEL  
ROUE



EN 16630

-  h > 1,4 m.
-  0 m.
-  53 Kg.
-  1,04 x 1,06 x 2,47 m.
-  4,19 x 3,94 m.
-  14,62 m<sup>2</sup>.







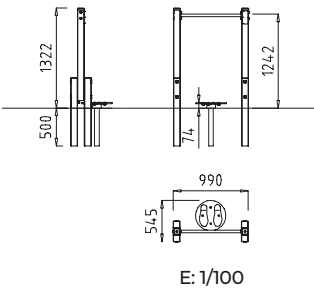

## DP600A4

GIRO CADERAS  
HIP ROTATOR  
VIREMENT DES HANCHES



EN 16630

-  h > 1,4 m.
-  0,07 m.
-  17 Kg.
-  1 x 2,7 x 1,81 m.
-  3,99 x 3,54 m.
-  12,21 m<sup>2</sup>.







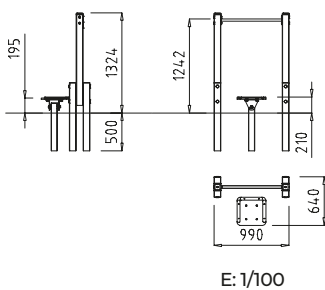

## DP600A3

BALANCEO CADERAS  
HIP SEESAW  
EQUILIBRE DES HANCHES



EN 16630

-  h > 1,4 m.
-  0,21 m.
-  17 Kg.
-  1 x 2,7 x 1,81 m.
-  3,99 x 3,64 m.
-  12,43 m<sup>2</sup>.



## DP600A2

PELDAÑOS  
STEPS  
ECHELONS

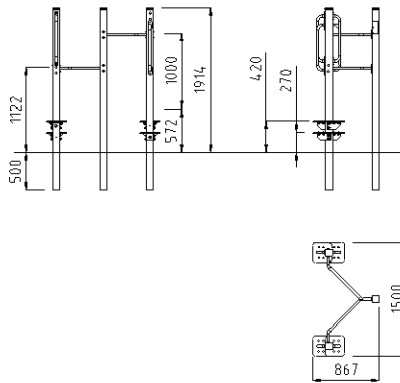

E: 1/100



EN 16630

- h > 1,4 m.
- 0,57 m.
- 55 Kg.
- 1,5 x 0,86 x 2,41 m.
- 4,50 x 3,86 m.
- 15,45 m².



## MB018 DP610

BANCO DE PEDALES  
PEDAL BENCH  
BANC DE PÉDALÉES

### MB018:

banco  
bench  
Banc.

### DP610:

Pedales. 2 Unidades.  
Pedals. 2 Units.  
Pédalées. 2 Unités.



EN 16630

- h > 1,4 m.
- 0,43 m.
- 40 Kg.
- 2 x 0,73 x 0,87 m.
- 5 x 4,24 m.
- 19,26 m².

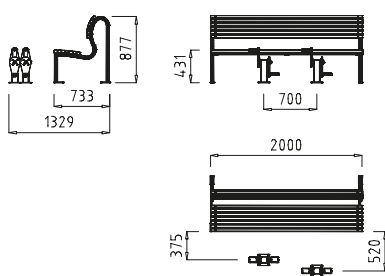

MB018 + DP610 | E: 1/100

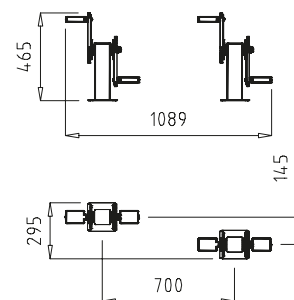

DP610 | E: 1/50

## DP601B2

PARALELAS  
PARALLEL BARS  
PARALLÈLES

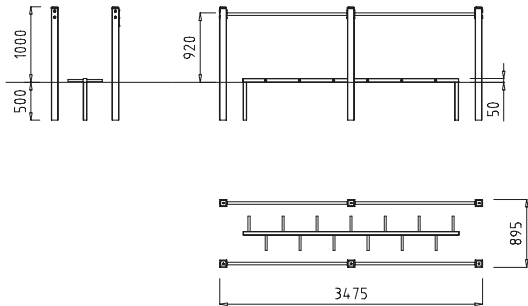

E: 1/100



EN 16630

- h > 1,4 m.
- 0,05 m.
- 37 Kg.
- 0,45 x 0,54 x 2,85 m.
- 6,47 x 3,89 m.
- 23,23 m².



## DP601B3

DEDOS  
FINGERS  
DOIGTS

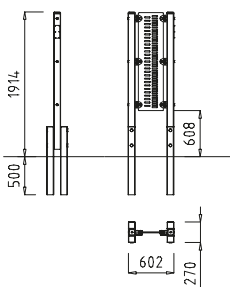

E: 1/100



EN 16630

- h > 1,4 m.
- 0 m.
- 37 Kg.
- 0,27 x 0,60 x 2,41 m.
- 3,6 x 3,27 m.
- 9,85 m².



## DP602C1

ESTIRAMIENTO PIERNAS  
LEG STRETCHING  
ÉTIREMENT DES JAMBES

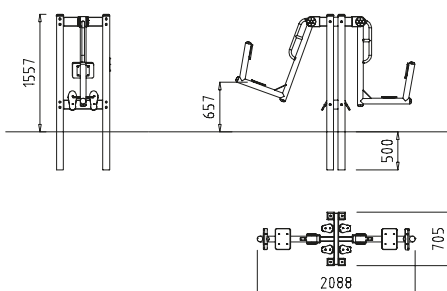

E: 1/100



EN 16630

- h > 1,4 m.
- 0,65 m.
- 63 Kg.
- 2,22 x 0,7 x 2,76 m.
- 5,68 x 3,7 m.
- 19,10 m².



## DP602C2

GIRO MUÑECAS  
WRIST ROTATION  
VIREMENT DES POIGNETS

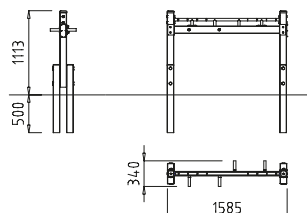

E: 1/100



- h > 1,4 m.
- 0 m.
- 36 Kg.
- 1,58 x 0,34 x 1,61 m.
- 4,58 x 3,34 m.
- 13,04 m<sup>2</sup>.



## DP603D2

SERPIENTE  
SNAKE  
SERPENT

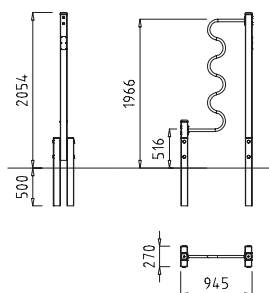

E: 1/100



- h > 1,4 m.
- 0 m.
- 19 Kg.
- 0,27 x 0,9 x 2,55 m.
- 3,94 x 3,27 m.
- 10,95 m<sup>2</sup>.



## DP603D1

ESTIRAMIENTO ESPALDA  
BACK STRETCHING  
ÉTIREMENT DU DOS

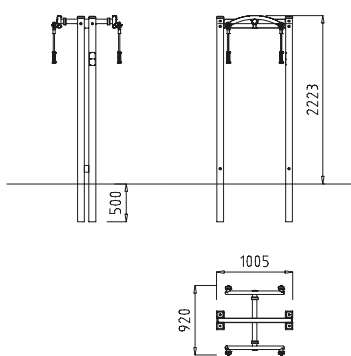

E: 1/100



- h > 1,4 m.
- 0 m.
- 45 Kg.
- 2,71 x 0,8 x 0,99 m.
- 4 x 3,92 m.
- 13,76 m<sup>2</sup>.

