

CARACTERISTICAS / FEATURES

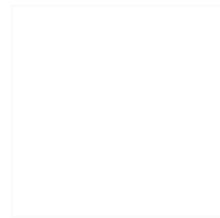

Material hormigón Petra 1
Acabado decapado e hidrofugado
Dimensiones l. 80, a. 80, h. 100 cm
Color ver carta de colores
Fijación apoyado por su propio peso o mediante resina epoxi
Peso 700 Kg
Palet 115 x 115 cm

Material precast concrete Petra 1
Finish scaled and waterproofed
Dimensions l. 80, w. 80, h. 100 cm
Colour see colour catalogue
Fixing resting on the ground or with epoxy resin
Weight 700 Kg
Pallet 115 x 115 cm

KRUK-100

diseñador / design: magourban

GEOMETRIA / GEOMETRY

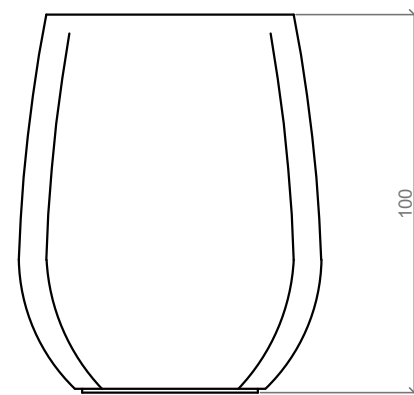

ALÇAT / FRONT VIEW

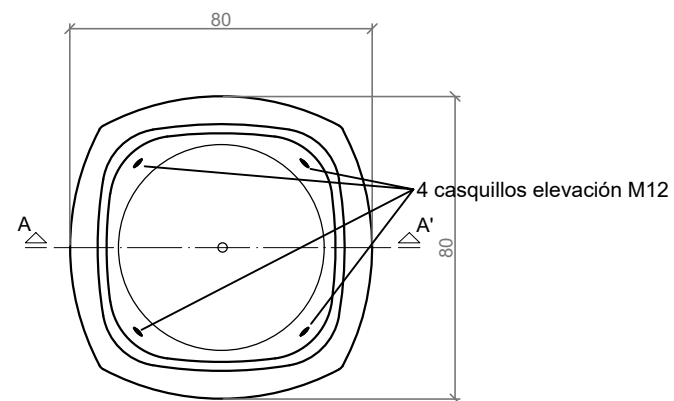

PLANTA / TOP VIEW

MANIPULACIÓN E INSTALACIÓN / HANDLING AND INSTALLATION

Elevación / Hoisting
 P= 700 Kg



ESPECIFICACIONES / SPECIFICATIONS

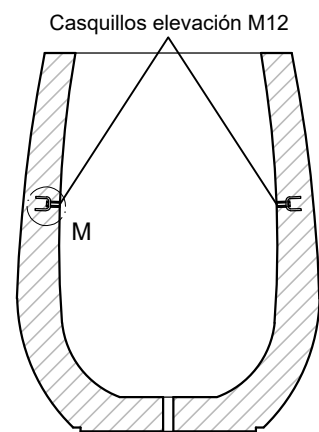

SECCIÓN A-A' / SECTION A-A'

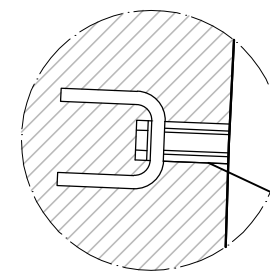

DETALLE M / DETAIL M

Casquillo roscado elevación M12
 Threaded sleeve M12 lifting

Buff'Hyères
 Collectivités

MOBILIERS & AMÉNAGEMENTS URBAIN

06 32 46 92 74 - MOBILIER@BHC83.FR

CARACTERÍSTICAS / FEATURES

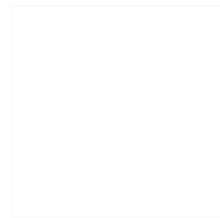

Material hormigón Petra 1
Acabado decapado e hidrofugado
Dimensiones l. 100, a. 100, h. 90 cm
Color ver carta de colores
Fijación apoyado por su propio peso o mediante resina epoxi
Peso 860 Kg
Palet 115 x 115 cm

Material precast concrete Petra 1
Finish scaled and waterproofed
Dimensions l. 100, w. 100, h. 90 cm
Colour see colour catalogue
Fixing resting on the ground or with epoxy resin
Weight 860 Kg
Pallet 115 x 115 cm

diseñador / design: magourban

KRUK-90

GEOMETRIA / GEOMETRY

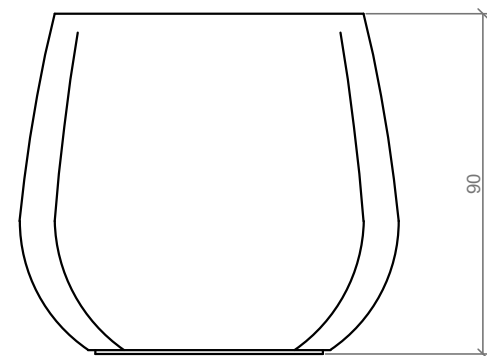

ALÇAT / FRONT VIEW

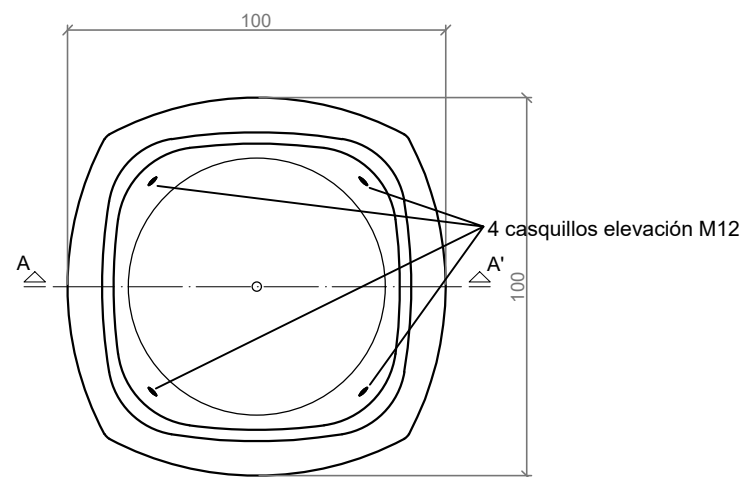

PLANTA / TOP VIEW

MANIPULACIÓN E INSTALACIÓN / HANDLING AND INSTALLATION

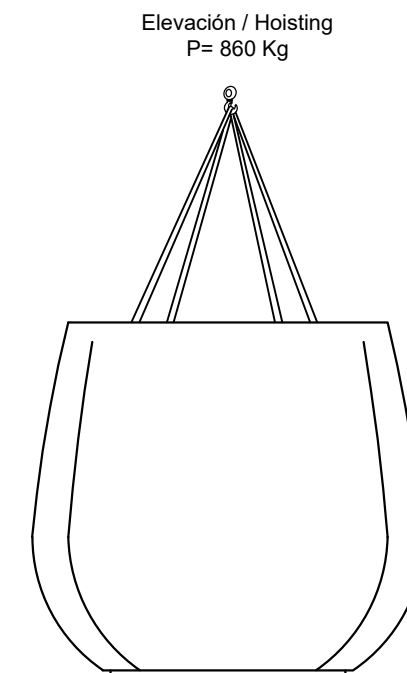

ESPECIFICACIONES / SPECIFICATIONS

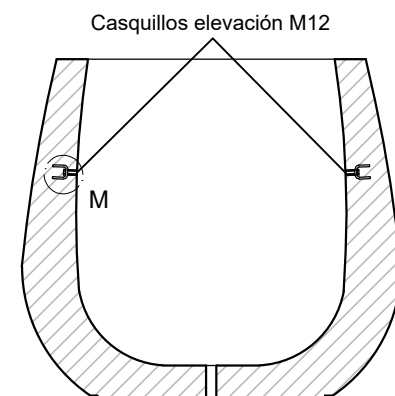

SECCIÓN A-A' / SECTION A-A'

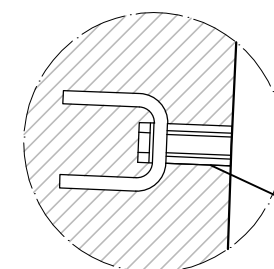

DETALLE M / DETAIL M

Casquillo roscado elevación M12
 Threaded sleeve M12 lifting

Buff'Hyères

Collectivités

MOBILIERS & AMÉNAGEMENTS URBAIN

06 32 46 92 74 - MOBILIER@BHC83.FR

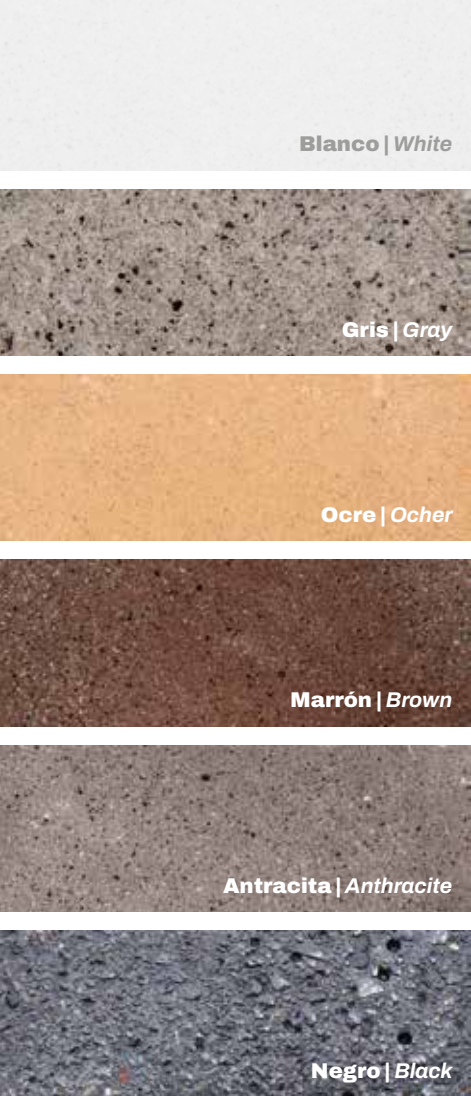

Blanco | White

Gris | Gray

Ocre | Ocher

Marrón | Brown

Antracita | Anthracite

Negro | Black

colores | colours



Amarillo | Yellow

Naranja | Orange

Rojo | Red

Azul | Blue

Verde | Green

colores opcionales (más colores disponibles)
optional colours (more available colours)

Petra 1

Personalizable
Customisable

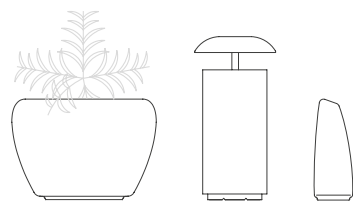
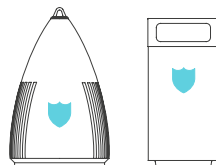

acabados de superficie

Disponibles en:
jardineras, recogida de residuos y límites

surface finishes

Available:
planters, waste collection and bollards



Corten



Negro Grafito | Black Graphite

SMC (UHPC)

acabado liso + antigraffiti

smooth finish + antigraffiti

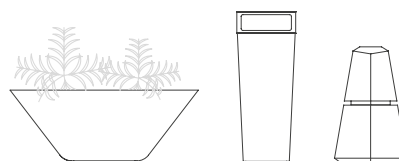

acabados de superficie

Disponibles en:
jardineras, recogida de residuos y límites

surface finishes

Available:
planters, waste collection and bollards



Corten



Golden

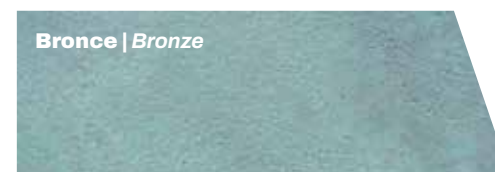

Bronce | Bronze



Negro Grafito | Black Graphite

colores | colours

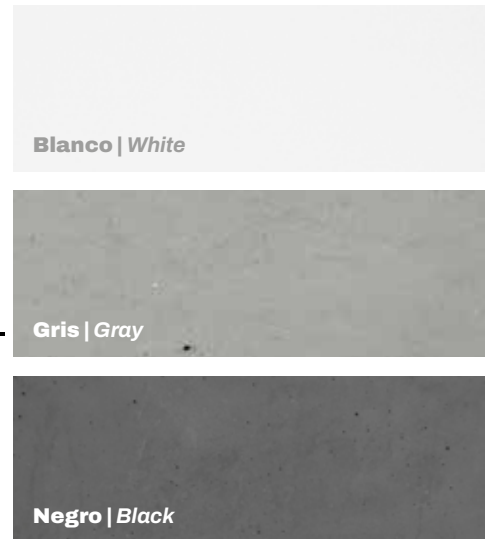

Blanco | White

Gris | Gray

Negro | Black

Buff'Hyères

Collectivités
MOBILIERS & AMÉNAGEMENTS URBAIN

06 32 46 92 74 - MOBILIER@BHC83.FR